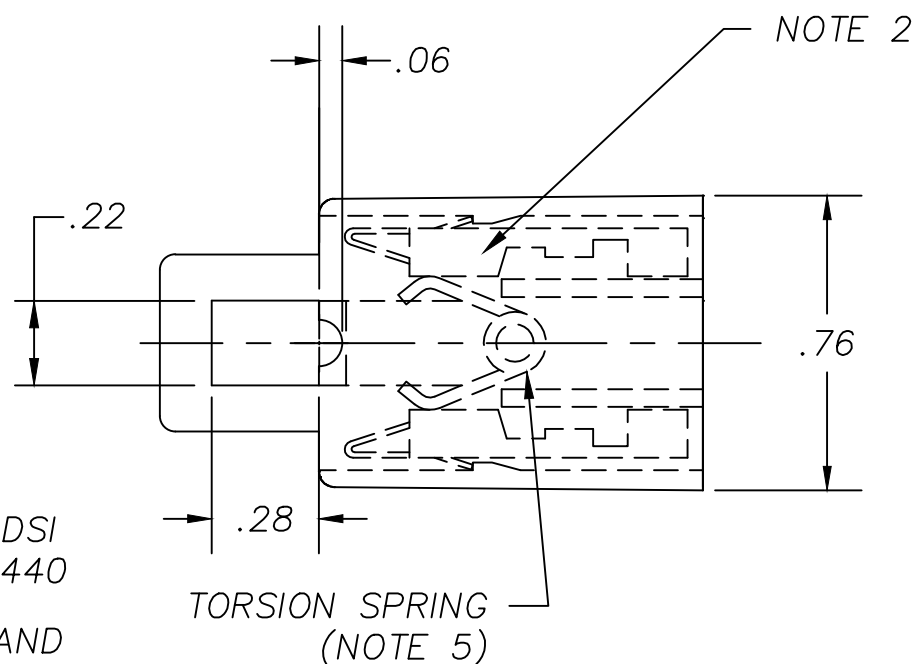
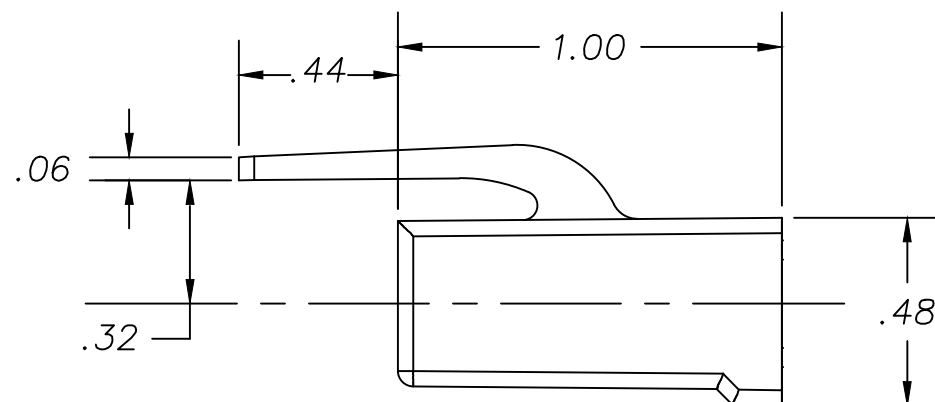

TABLE #2

DSI PART NUMBER	COLOR
96525-GY	GRAY



NOTES:

- 1-TTHIS DIMENSION AND LOCKING CLIP MATE WITH DSI 6500 AND 6520 SERIES SEAT SWITCHES AND 6440 SERIES SNAP MOUNT SWITCH.
- 2-PACKARD 56 SERIES FEMALE TERMINALS WITH AND WITHOUT MATING NIB (2) INSTALLED BY CUSTOMER. (SEE TABLE 1.)
- 3-TERMINALS OTHER THAN THOSE SPECIFIED IN TABLE #1 ABOVE MAY DEGRADE THE PERFORMANCE OF THE SHORTING FEATURE.
- 4-HARNESS TENSION ON CONNECTOR MUST BE MINIMIZED.
- 5-CONNECTOR SHOWN IN FAIL SAFE MODE (CLOSED CIRCUIT). SPRING MOVES AWAY FROM TERMINALS WHEN CONNECTED TO SWITCH.
- 6-TTHIS PRODUCT IS COVERED BY U.S. PATENT #4,894,019
- 7-PLASTIC COMPONENTS ARE POLYPROPYLENE.
- 8-DATE CODE INDICATING MONTH, DAY, AND YEAR TO BE EVIDENT ON EXTERIOR SURFACE OF HOUSING.

REVISIONS

E	ADDED TABLE #2, CR 963	04/30/97	TW
F	REDESIGN, CR 1269B	08/11/99	JH
G	IMPLEMENT DATE CODE, CR 1320	08/17/99	JH
H	SHORTENED WING SLOT, CR 1364	01/07/00	JH
J	REM. BLACK PP, ADDED "A", CR1627	02/24/06	MA

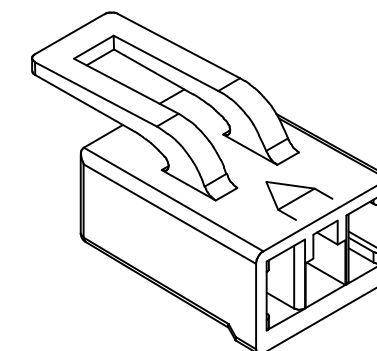

TABLE #1

PACKARD ELECTRIC TERMINAL P/N's			
WIRE GA.	PLATED	UNPLATED	LOCKING NIB
18 GA.	2965510	2962572	NO
16 GA.	2965867	2962573	NO
18-20 GA.	12124523	N/A	NO
18-20 GA.	12124513	N/A	NO
14-16 GA.	12124515	N/A	YES
14-16 GA.	12124517	N/A	NO
12 GA.	12124518	N/A	YES
12 GA.	12124519	N/A	NO

DELTA SYSTEMS, INC. DOES NOT ASSUME ANY LIABILITY ARISING OUT OF THE MISAPPLICATION OF ANY PRODUCT

COMPUTER GENERATED DRAWING - NO MANUAL CHANGES ALLOWED

UNLESS OTHERWISE SPECIFIED DIMENSIONS ARE IN INCHES TOLERANCES ARE:
 .xx± .02 .xxx± .005 ANG± 1°
 DO NOT SCALE DRAWING

DRAWN MA	DATE 10/19/05
CHECKED JM	DATE 01/31/06
MATERIAL SEE NOTE 7	
FINISH FOR COLOR OPTIONS SEE TABLE 2	

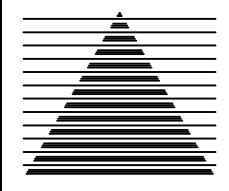
		DELTA SYSTEMS INC. STREETSBORO, OHIO 44241	
TITLE SHORTING CONNECTOR ASSEMBLY			
SIZE B	DWG. NO. 96525		
SCALE 2X	PROJECT NO. EX311	REV J	