

REVISIONS	
~	INITIAL RELEASE, CN 1131
	05/09/06 MA

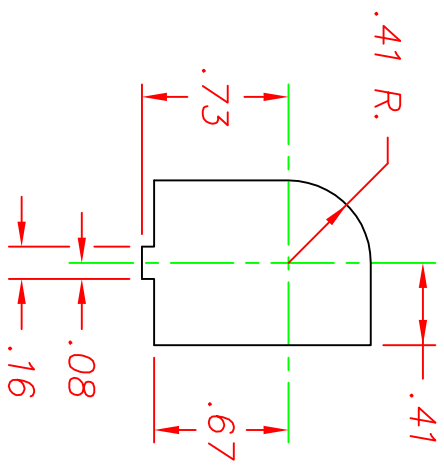

.040 - .150 MOTION TO OPEN CONTACTS

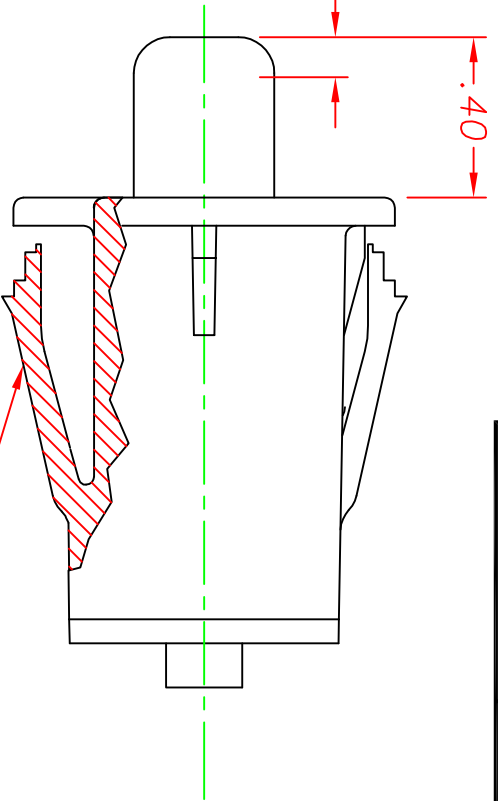

SNAP WINGS TO ACCOMMODATE PANEL THICKNESSES OF .055, .115, AND .140, INCLUDING PAINT AND DECALS.

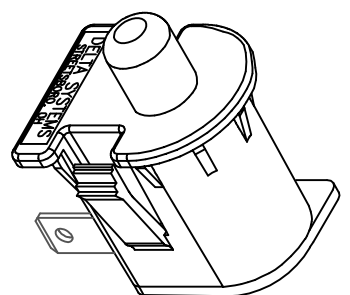

ISOMETRIC VIEW

SUGGESTED MOUNTING HOLE
(SCALE: FULL)

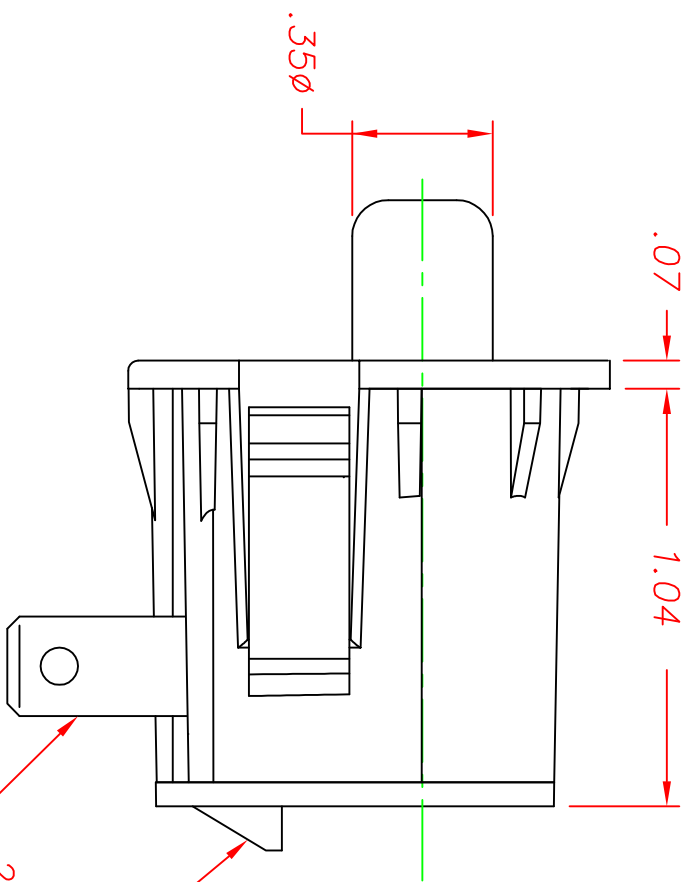
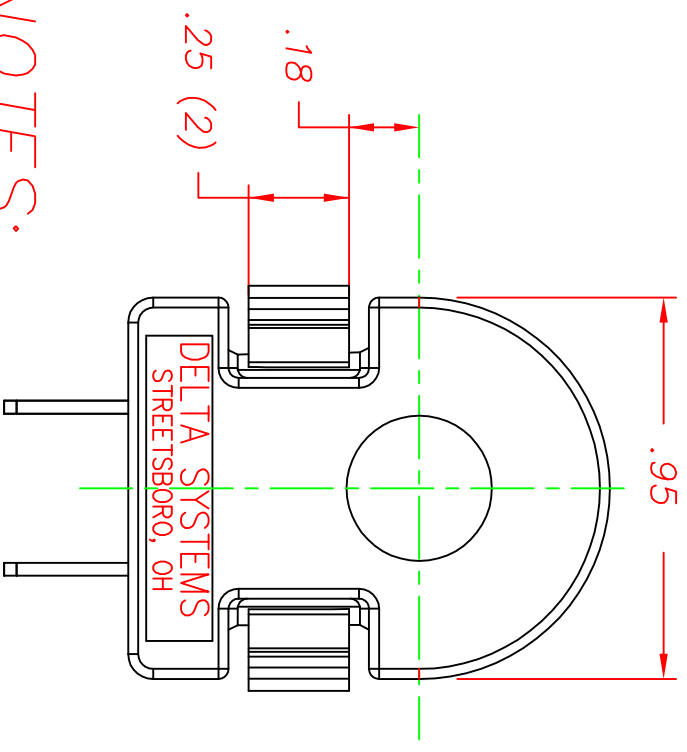

TERMINAL PATTERN & LOCKING TAB TO MATE WITH EITHER DSI 96525 SERIES OR 96526 SERIES CONNECTORS
 .25 x .032 MALE BLADE TERMINALS (2)

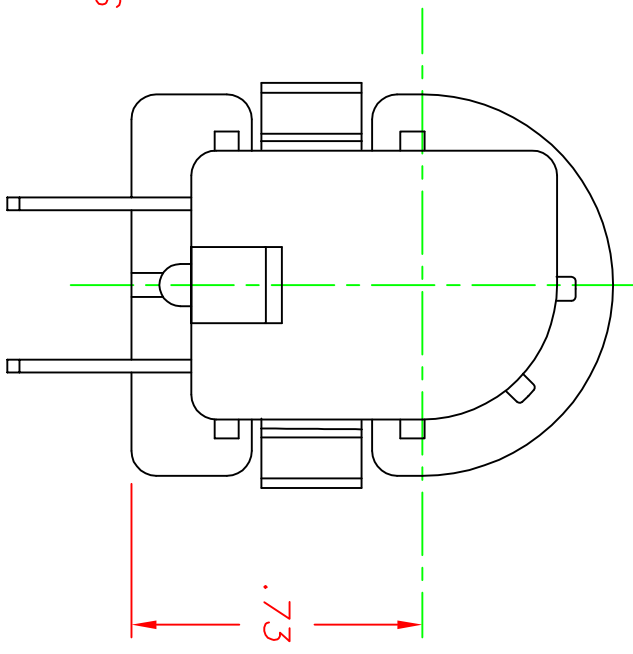

NOTES:

- 1-PLASTIC PARTS ARE FLAME RETARDANT, UV STABLE THERMOPLASTIC. TERMINALS ARE NICKEL-PLATED BRASS. INTERNAL CONTACT IS BERYLLIUM COPPER.
- 2-PART NO. AND DATE CODE INDICATING YEAR, MONTH, AND DAY OF MONTH MANUFACTURED STAMPED ON HOUSING.
- 3-INTEGRITY OF WELD & SWITCH FUNCTIONALITY TESTED AFTER ASSEMBLY.
- 4-THIS PRODUCT COVERED BY THE FOLLOWING U.S. PATENT; 4,812,604. OTHER PATENTS APPLIED FOR.
- 5-ELECTRICAL RATING: 5A @ 12-14 VDC.
- 6-LIFE AT RATED LOAD: 10K CYCLES INDUCTIVE, 75K CYCLES RESISTIVE.
- 7-MECHANICAL LIFE: 300,000 CYCLES.
- 8-OPERATING TEMPERATURE: -20°F TO 150°F.
- 9-CONNECTION EFFORT: UP TO 10 LBS. PER TERMINAL
- 10-THIS SWITCH IS RECOGNIZED UNDER CATEGORY UL 583.(INDUSTRIAL TRUCK ACCESSORIES, BATTERY POWERED-COMPONENT, FILE# YCFT2.AU3028)

DELTA SYSTEMS, INC. DOES NOT ASSUME ANY LIABILITY ARISING OUT OF THE MISAPPLICATION OF ANY PRODUCT
 UNLESS OTHERWISE SPECIFIED DIMENSIONS ARE IN INCHES TOLERANCES ARE:
 .XXX# .02 .XXX# .005 ANG# 1'

DRAWN	DATE
MA	05/09/06
CHECKED	DATE
JM	05/10/06
MATERIAL NOTE 1	
FINISH WHITE	

 DELTA SYSTEMS INC. STREETSBORO, OHIO 44241			
SNAP-MOUNT SWITCH NORMALLY OPEN			
SIZE	DWG. NO.	PROJECT NO.	REV
B	6440-16	EX-311	~
SCALE	SHEET	OF	
2X	1	1	